

SECTION **FAX**
FRONT AXLE

A
B
C

FAX

CONTENTS

E

SYMPTOM DIAGNOSIS	2	Removal and Installation (GT-R certified NISSAN dealer)	8	F
NOISE, VIBRATION AND HARSHNESS (NVH) TROUBLESHOOTING	2	Inspection (GT-R certified NISSAN dealer)	9	
NVH Troubleshooting Chart	2	FRONT DRIVE SHAFT BOOT	10	G
PRECAUTION	3	Exploded View (GT-R certified NISSAN dealer)	10	
PRECAUTIONS	3	WHEEL SIDE	11	H
Precaution for Supplemental Restraint System (SRS) "AIR BAG" and "SEAT BELT PRE-TENSIONER"	3	WHEEL SIDE : Removal and Installation (GT-R certified NISSAN dealer)	11	
Precaution Necessary for Steering Wheel Rotation after Battery Disconnect	3	FINAL DRIVE SIDE	13	I
General Precautions	3	FINAL DRIVE SIDE : Removal and Installation (GT-R certified NISSAN dealer)	13	
Precautions for Wheel Hub and Bearing Assembly and Steering Knuckle (GT-R certified NISSAN dealer)	3	Inspection (GT-R certified NISSAN dealer)	13	J
Precautions for Drive Shaft (GT-R certified NISSAN dealer)	4	FRONT DRIVE SHAFT	14	
PREPARATION	5	Exploded View (GT-R certified NISSAN dealer)	14	K
PREPARATION	5	LEFT SIDE	15	
Special Service Tool (GT-R certified NISSAN dealer)	5	LEFT SIDE : Removal and Installation (GT-R certified NISSAN dealer)	15	L
Commercial Service Tool (GT-R certified NISSAN dealer)	5	RIGHT SIDE	15	
ON-VEHICLE MAINTENANCE	6	RIGHT SIDE : Removal and Installation (GT-R certified NISSAN dealer)	15	M
FRONT WHEEL HUB AND KNUCKLE	6	WHEEL SIDE	16	
Inspection	6	WHEEL SIDE : Disassembly and Assembly (GT-R certified NISSAN dealer)	16	N
FRONT DRIVE SHAFT	7	FINAL DRIVE SIDE	18	
Inspection	7	FINAL DRIVE SIDE : Disassembly and Assembly (GT-R certified NISSAN dealer)	18	O
ON-VEHICLE REPAIR	8	Inspection (GT-R certified NISSAN dealer)	20	
FRONT WHEEL HUB AND KNUCKLE	8	SERVICE DATA AND SPECIFICATIONS (SDS)	22	P
Exploded View	8	SERVICE DATA AND SPECIFICATIONS (SDS)	22	
		Wheel Bearing (GT-R certified NISSAN dealer)	22	
		Drive Shaft (GT-R certified NISSAN dealer)	22	

NOISE, VIBRATION AND HARSHNESS (NVH) TROUBLESHOOTING

< SYMPTOM DIAGNOSIS >

SYMPTOM DIAGNOSIS

NOISE, VIBRATION AND HARSHNESS (NVH) TROUBLESHOOTING

NVH Troubleshooting Chart

INFOID:000000003850224

Use chart below to find the cause of the symptom. If necessary, repair or replace these parts.

Symptom		Possible cause and SUSPECTED PARTS		Reference page										
		Excessive joint angle	Joint sliding resistance	Imbalance	Improper installation, looseness	Parts interference	Wheel bearing damage	FRONT AXLE AND FRONT SUSPENSION	FRONT AXLE	TIRE	ROAD WHEEL	DRIVE SHAFT	BRAKE	STEERING
DRIVE SHAFT	Noise	x	x					x	x	x	x		x	x
	Shake	x		x				x	x	x	x		x	x
FRONT AXLE	Noise				x	x	x	x		x	x	x	x	x
	Shake				x	x	x	x		x	x	x	x	x
	Vibration				x	x	x	x		x		x		x
	Shimmy				x	x		x		x	x		x	x
	Judder				x			x		x	x		x	x
	Poor quality ride or handling				x	x		x		x	x			

x: Applicable

PRECAUTIONS

< PRECAUTION >

PRECAUTION

PRECAUTIONS

Precaution for Supplemental Restraint System (SRS) "AIR BAG" and "SEAT BELT PRE-TENSIONER"

INFOID:000000004115355

The Supplemental Restraint System such as "AIR BAG" and "SEAT BELT PRE-TENSIONER", used along with a front seat belt, helps to reduce the risk or severity of injury to the driver and front passenger for certain types of collision. This system includes seat belt switch inputs and dual stage front air bag modules. The SRS system uses the seat belt switches to determine the front air bag deployment, and may only deploy one front air bag, depending on the severity of a collision and whether the front occupants are belted or unbelted. Information necessary to service the system safely is included in the "SRS AIRBAG" and "SEAT BELT" of this Service Manual.

WARNING:

- To avoid rendering the SRS inoperative, which could increase the risk of personal injury or death in the event of a collision which would result in air bag inflation, all maintenance must be performed by an authorized NISSAN/INFINITI dealer.
- Improper maintenance, including incorrect removal and installation of the SRS, can lead to personal injury caused by unintentional activation of the system. For removal of Spiral Cable and Air Bag Module, see the "SRS AIRBAG".
- Never use electrical test equipment on any circuit related to the SRS unless instructed to in this Service Manual. SRS wiring harnesses can be identified by yellow and/or orange harnesses or harness connectors.

Precaution Necessary for Steering Wheel Rotation after Battery Disconnect

INFOID:000000004115357

NOTE:

- Before removing and installing any control units, first turn the push-button ignition switch to the LOCK position, then disconnect both battery cables.
- After finishing work, confirm that all control unit connectors are connected properly, then re-connect both battery cables.
- Always use CONSULT-III to perform self-diagnosis as a part of each function inspection after finishing work. If a DTC is detected, perform trouble diagnosis according to self-diagnosis results.

This vehicle is equipped with a push-button ignition switch and a steering lock unit.

If the battery is disconnected or discharged, the steering wheel will lock and cannot be turned.

If turning the steering wheel is required with the battery disconnected or discharged, follow the procedure below before starting the repair operation.

OPERATION PROCEDURE

1. Connect both battery cables.

NOTE:

Supply power using jumper cables if battery is discharged.

2. Turn the push-button ignition switch to ACC position.
(At this time, the steering lock will be released.)
3. Disconnect both battery cables. The steering lock will remain released with both battery cables disconnected and the steering wheel can be turned.
4. Perform the necessary repair operation.
5. When the repair work is completed, re-connect both battery cables. With the brake pedal released, turn the push-button ignition switch from ACC position to ON position, then to LOCK position. (The steering wheel will lock when the push-button ignition switch is turned to LOCK position.)
6. Perform self-diagnosis check of all control units using CONSULT-III.

General Precautions

INFOID:000000004173817

CAUTION:

After finishing servicing, check that all the tools and waste are stored in a customary place.

Precautions for Wheel Hub and Bearing Assembly and Steering Knuckle (GT-R certi-

PRECAUTIONS

< PRECAUTION >

fied NISSAN dealer)

INFOID:000000003977625

- Always tighten each mounting bolt and nut to the specified torque when they are cold.
- When performing removal or installation work, check for any foreign materials entered. If any, eliminate or clean them.
- Check the wheel hub and bearing assembly for looseness or smooth movement to the direction rotation.

Precautions for Drive Shaft (GT-R certified NISSAN dealer)

INFOID:000000003850227

Observe the following precautions when disassembling and assembling drive shaft.

- Never disassemble joint sub-assembly because it is non-overhaul parts.
- Perform work in a location which is as dust-free as possible.
- Clean the parts before disassembling and assembling.
- Prevent the entry of foreign objects must be taken into account during disassembly of the service location.
- Reassemble disassembled parts carefully in the correct order. If work is interrupted, a clean cover must be placed over parts.
- Use paper waste. Never fabric shop cloths must not be used because of the danger of lint adhering to parts.
- Clean disassembled parts (except for rubber parts) with kerosene which shall be removed by blowing with air or wiping with paper waste.

www.gtr-store.eu

PREPARATION

< PREPARATION >

PREPARATION

PREPARATION

Special Service Tool (GT-R certified NISSAN dealer)

INFOID:000000003850228

The actual shapes of Kent-Moore tools may differ from those of the special service tools illustrated here.

Tool number (Kent-Moore No.) Tool name	Description
KV40107300 (-) Boot band crimping tool	Installing boot band
KV40107500 (-) Drive shaft attachment	Removing drive shaft
KV38107900 (-) Protector a: 32 mm (1.26 in) dia.	Installing drive shaft

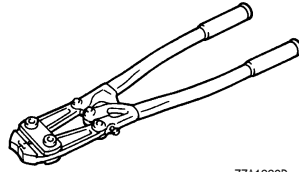

ZZA12290



ZZA12300

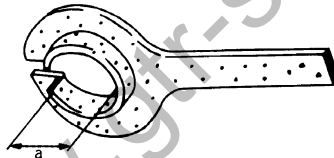

PDIA1183J

Commercial Service Tool (GT-R certified NISSAN dealer)

INFOID:000000003850229

Tool name	Description
Power tool	Loosening bolts and nuts

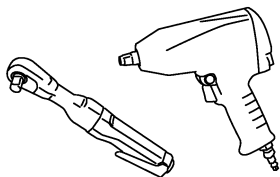

PB1C0190E

A
B
C
FAX
E
F
G
H
I
J
K
L
M
N
O
P

FRONT WHEEL HUB AND KNUCKLE

< ON-VEHICLE MAINTENANCE >

ON-VEHICLE MAINTENANCE

FRONT WHEEL HUB AND KNUCKLE

Inspection

INFOID:000000003850230

MOUNTING INSPECTION

Check that the mounting conditions (looseness, back lash) of each component and component conditions (wear, damage) are normal.

WHEEL BEARING INSPECTION

- Move wheel hub and bearing assembly in the axial direction by hand. Check there is no looseness of wheel bearing.

Standard

Axial end play : Refer to [FAX-22, "Wheel Bearing \(GT-R certified NISSAN dealer\)"](#).

- Rotate wheel hub and check is no unusual noise or other irregular conditions. If there is any of abnormal conditions, replace wheel hub and bearing assembly.

www.gtr-store.eu

FRONT DRIVE SHAFT

< ON-VEHICLE MAINTENANCE >

FRONT DRIVE SHAFT

Inspection

INFOID:000000003850231

- Check drive shaft mounting point and joint for looseness and other damage.
- Check boot for cracks and other damage.

CAUTION:

Replace entire drive shaft assembly when noise or vibration occur from drive shaft.

A

B

C

FAX

E

F

G

H

I

J

K

L

M

N

O

P

www.gtr-store.eu

FRONT WHEEL HUB AND KNUCKLE

< ON-VEHICLE REPAIR >

ON-VEHICLE REPAIR

FRONT WHEEL HUB AND KNUCKLE

Exploded View

INFOID:000000003850222

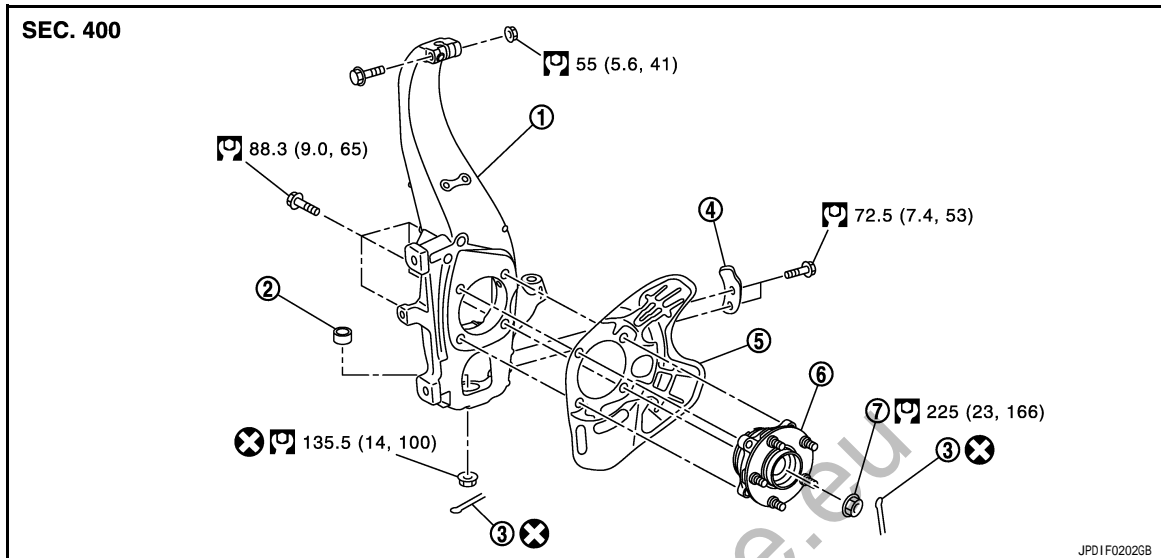

- | | | |
|-----------------------------|-----------------|-----------------------------------|
| 1. Steering knuckle | 2. Ball seat | 3. Cotter pin |
| 4. Steering support bracket | 5. Splash guard | 6. Wheel hub and bearing assembly |
| 7. Wheel hub lock nut | | |

Refer to [GI-4, "Components"](#) for the symbols in the figure.

Removal and Installation (GT-R certified NISSAN dealer)

INFOID:000000003977647

REMOVAL

1. Remove tires with power tool.
2. Remove wheel sensor and sensor harness. Refer to [BRC-115, "FRONT WHEEL SENSOR : Removal and Installation \(GT-R certified NISSAN dealer\)"](#).
3. Remove brake hose bracket. Refer to [BR-20, "FRONT : Exploded View"](#).
4. Remove caliper assembly mounting bolts. Hang caliper assembly in a place where it will not interfere with work. Refer to [BR-36, "BRAKE CALIPER ASSEMBLY : Exploded View \(GT-R certified NISSAN dealer\)"](#).
5. Remove disc rotor. Refer to [BR-36, "BRAKE CALIPER ASSEMBLY : Removal and Installation \(GT-R certified NISSAN dealer\)"](#).
6. Remove cotter pin, and then loosen wheel hub lock nut with power tool.
7. Patch wheel hub lock nut with a piece of wood. Hammer the wood to disengage wheel hub and bearing assembly from drive shaft.

CAUTION:

- Never place drive shaft joint at an extreme angle. Also be careful not to overextend slide joint.
- Never allow drive shaft to hang down without support for counterpart such as joint sub-assembly and the other parts.

NOTE:

Use a suitable puller, if wheel hub and bearing assembly and drive shaft cannot be separated even after performing the above procedure.

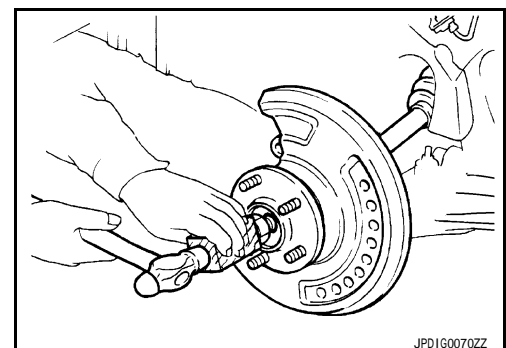

8. Remove wheel hub lock nut.
9. Remove wheel hub and bearing assembly, and then remove splash guard.

FRONT WHEEL HUB AND KNUCKLE

< ON-VEHICLE REPAIR >

10. Remove steering outer socket. Refer to [ST-19, "Exploded View"](#).
11. Remove cotter pin of transverse link, and then loosen mounting nut.
12. Separate steering knuckle from upper link.
13. Separate transverse link from steering knuckle so as not to damage ball joint boot using the ball joint remover, and then remove steering knuckle.

CAUTION:

Temporarily tighten the nut to prevent damage to threads and to prevent the ball joint remover from suddenly coming off.

14. Remove steering support bracket.

INSTALLATION

Note the following, and install in the reverse order of the removal.

- When assembling the shaft, never press it, but pull it until fully seated by tightening the wheel hub lock nut.
- Check that anticorrosive oil is applied to the thread of the drive shaft. If not, apply appropriate oil such as engine oil.
- If sufficient oil is not applied to the thread of the drive shaft, the wheel hub lock nut may be seized and the tightening torque reaches the specified limit prematurely. It may cause looseness or abnormal noises.
- Perform the final tightening of each of parts under unladen conditions, which were removed when removing wheel hub and bearing assembly and steering knuckle.
- Never reuse cotter pin.

Inspection (GT-R certified NISSAN dealer)

INFOID:000000003977648

INSPECTION AFTER REMOVAL

Check components for deformation, cracks and other damage. Replace it if necessary.

Ball Joint Inspection

Check boots of transverse link, upper link and steering outer socket ball joint for breakage, axial play, and torque. Refer to [FSU-14, "Inspection \(GT-R certified NISSAN dealer\)"](#), [FSU-16, "Inspection \(GT-R certified NISSAN dealer\)"](#) and [ST-24, "Inspection \(GT-R certified NISSAN dealer\)"](#).

INSPECTION AFTER INSTALLATION

1. Check wheel sensor harness for proper connection. Refer to [BRC-115, "FRONT WHEEL SENSOR : Removal and Installation \(GT-R certified NISSAN dealer\)"](#).
2. Check the wheel alignment. Refer to [FSU-7, "Inspection"](#).
3. Adjust neutral position of steering angle sensor. Refer to [BRC-10, "ADJUSTMENT OF STEERING ANGLE SENSOR NEUTRAL POSITION : Special Repair Requirement \(GT-R certified NISSAN dealer\)"](#).

A
B
C
E
F
G
H
I
J
K
L
M
N
O
P

FAX

FRONT DRIVE SHAFT BOOT

< ON-VEHICLE REPAIR >

FRONT DRIVE SHAFT BOOT

Exploded View (GT-R certified NISSAN dealer)

INFOID:000000003977649

LEFT SIDE

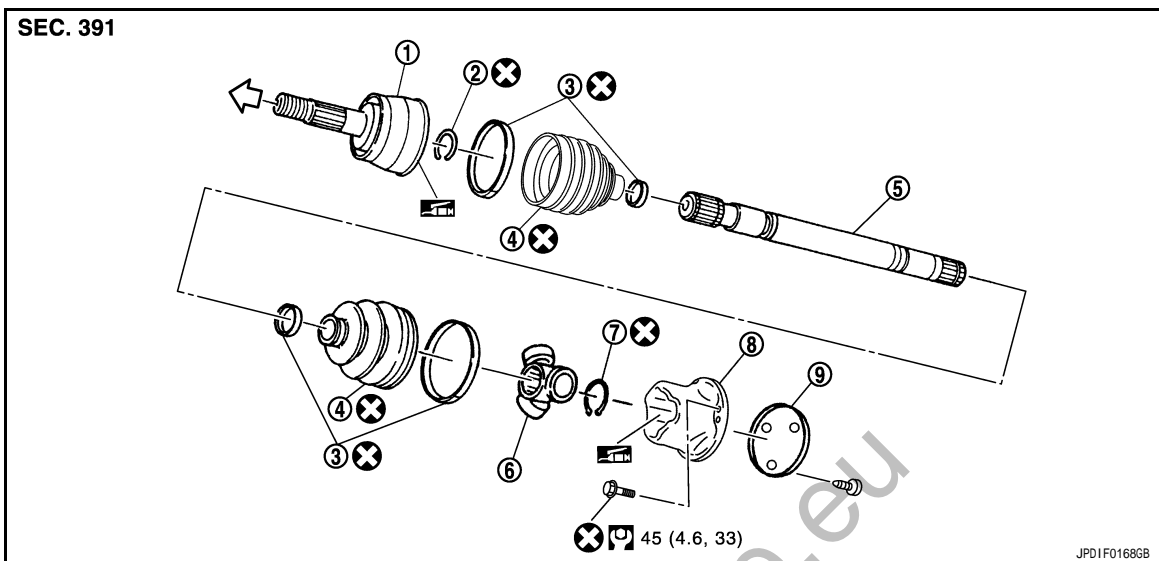

- | | | |
|-----------------------|------------------|--------------------|
| 1. Joint sub-assembly | 2. Circular clip | 3. Boot band |
| 4. Boot | 5. Shaft | 6. Spider assembly |
| 7. Snap ring | 8. Housing | 9. Plug |

⇐: Wheel side

: NISSAN genuine grease or an equivalent.

Refer to [GI-4, "Components"](#) for symbols not described on the above.

RIGHT SIDE

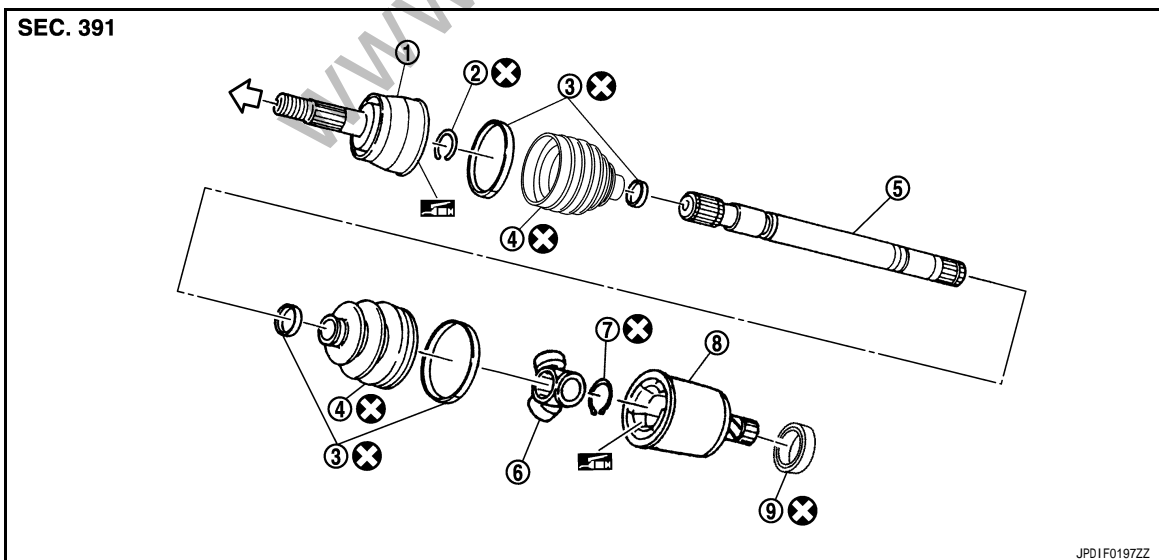

- | | | |
|-----------------------|------------------|--------------------|
| 1. Joint sub-assembly | 2. Circular clip | 3. Boot band |
| 4. Boot | 5. Shaft | 6. Spider assembly |
| 7. Snap ring | 8. Housing ring | 9. Dust shield |

⇐: Wheel side

FRONT DRIVE SHAFT BOOT

< ON-VEHICLE REPAIR >

: NISSAN genuine grease or an equivalent.

Refer to [GI-4, "Components"](#) for symbols not described on the above.

WHEEL SIDE

WHEEL SIDE : Removal and Installation (GT-R certified NISSAN dealer)

INFOID:000000003977650

REMOVAL

1. Remove tires with power tool.
2. Remove steering knuckle. Refer to [FAX-8, "Exploded View"](#).
3. Remove boot bands, and then remove boot from joint sub-assembly.
4. Screw drive shaft puller (A) 30 mm (1.18 in) or more into the thread of joint sub-assembly, and pull joint sub-assembly with a sliding hammer (B) from shaft.

CAUTION:

- Align a sliding hammer and drive shaft and remove them by pulling firmly and uniformly.
- If joint sub-assembly cannot be pulled out, try after removing drive shaft from vehicle.

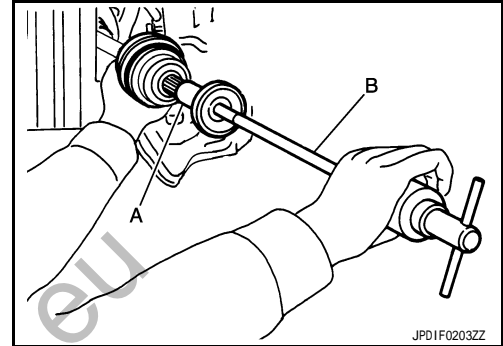

5. Remove circular clip (1) from shaft.
6. Remove boot from shaft.

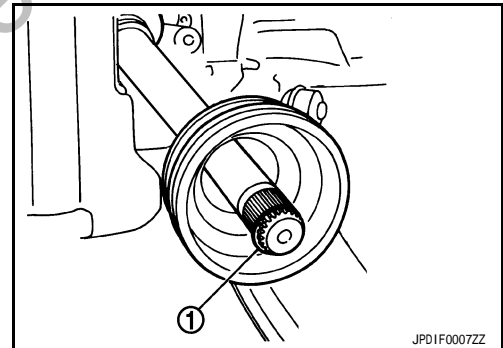

INSTALLATION

1. Clean the old grease on joint sub-assembly with paper waste.
2. Fill serration slot joint sub-assembly (1) with NISSAN genuine grease or equivalent until the serration slot and ball groove become full to the brim.

CAUTION:

After applying grease, use a paper waste to wipe it out old grease that has oozed out.

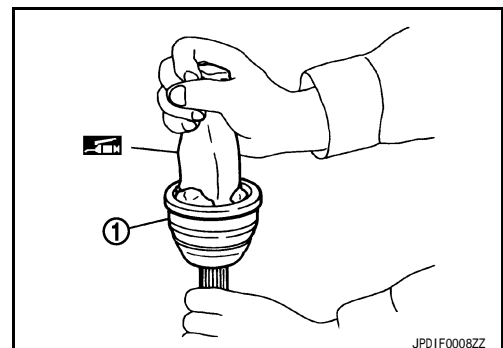

A
B
C
FAX
E
F
G
H
I
J
K
L
M
N
O
P

FRONT DRIVE SHAFT BOOT

< ON-VEHICLE REPAIR >

3. Wrap serration on shaft with tape (A) to protect the boot from damage. Install boot and boot bands to shaft.

CAUTION:

Never reuse boot and boot band.

4. Remove the tape wrapped around the serration on shaft.
5. Position circular clip on groove at the shaft edge.

CAUTION:

Never reuse circular clip.

NOTE:

Drive joint inserter is recommended when installing circular clip.

6. Align both center axes of the shaft edge and joint sub-assembly. Then assemble shaft with joint sub-assembly holding circular clip.

7. Install joint sub-assembly (1) to shaft using plastic hammer.

CAUTION:

Confirm that joint sub-assembly is correctly engaged while rotating drive shaft.

8. Apply the specified amount of grease into the boot inside from large diameter side of boot.

Standard

Grease amount : Refer to [FAX-22, "Drive Shaft \(GT-R certified NISSAN dealer\)"](#).

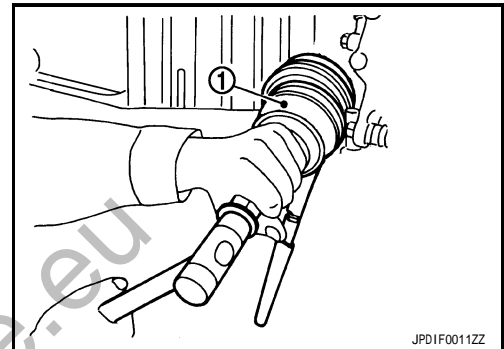
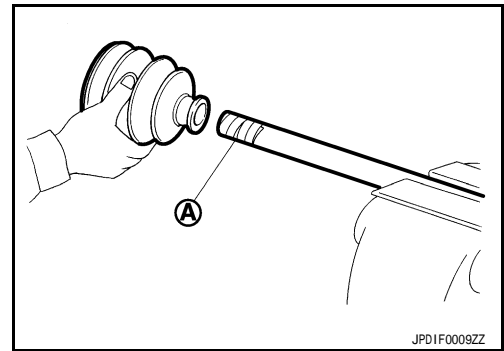

9. Install the boot into grooves (indicated by "*" marks) shown in the figure.

CAUTION:

If grease adheres to the boot mounting surface (indicated by "*" mark) on the shaft or joint sub-assembly, boot may come off. Remove all grease from the surface.

10. To prevent the deformation of the boot, adjust the boot installation length (L) to the specified value shown below by inserting the suitable tool into the inside of the boot from the large diameter side of the boot and discharging the inside air.

Standard

L : Refer to [FAX-22, "Drive Shaft \(GT-R certified NISSAN dealer\)"](#).

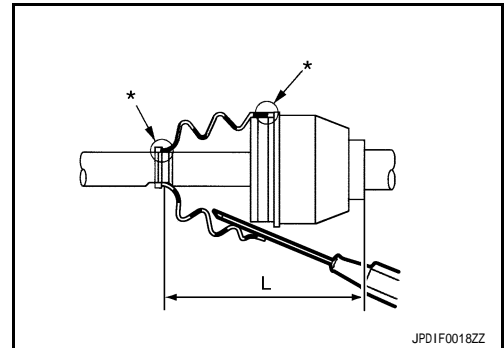

CAUTION:

- If the boot mounting length is outside the standard, it may cause breakage in the boot.
- Be careful not to touch the inside of the boot with a tip of tool.

11. Secure the ends of the boot with boot bands using the boot band crimping tool (A) [SST: KV40107300 (-)].

CAUTION:

Never reuse boot band.

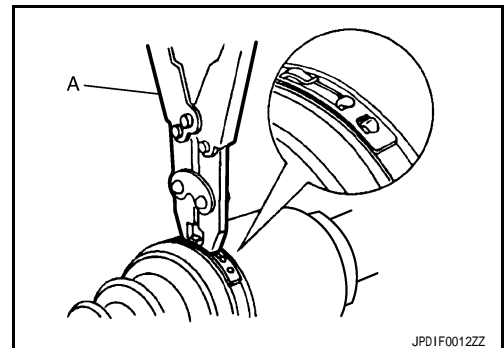

NOTE:

FRONT DRIVE SHAFT BOOT

< ON-VEHICLE REPAIR >

Secure boot band so that dimension (M) meets the specification as shown in the figure.

M : 2.0 – 3.0 mm (0.079 – 0.118 in)

- Secure joint sub-assembly and shaft, and then check that they are in the correct position when rotating boot. Install them with boot band when boot installation positions become incorrect.

CAUTION:

Never reuse boot band.

- Install steering knuckle. Refer to [FAX-8, "Exploded View"](#).

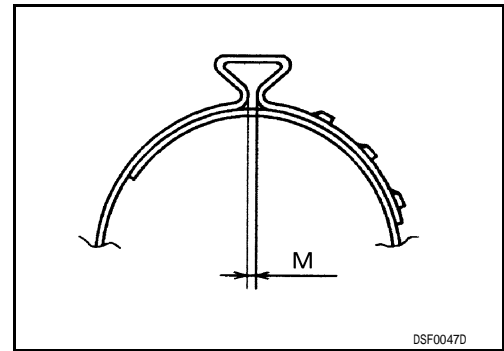

FINAL DRIVE SIDE

FINAL DRIVE SIDE : Removal and Installation (GT-R certified NISSAN dealer)

INFOID:000000003977651

NOTE:

Remove boot after removing drive shaft.

- Remove: refer to [FAX-15, "LEFT SIDE : Removal and Installation \(GT-R certified NISSAN dealer\)"](#) (left side), [FAX-15, "RIGHT SIDE : Removal and Installation \(GT-R certified NISSAN dealer\)"](#) (right side).
- Disassembly: refer to [FAX-18, "FINAL DRIVE SIDE : Disassembly and Assembly \(GT-R certified NISSAN dealer\)"](#).

Inspection (GT-R certified NISSAN dealer)

INFOID:000000003977652

INSPECTION AFTER REMOVAL

- Move joint up/down, left/right, and in the axial directions. Check for motion that is not smooth and for significant looseness.
- Check boot for cracks, damage and leakage of grease.
- Disassemble drive shaft and exchange malfunctioning part if there is a abnormal condition.

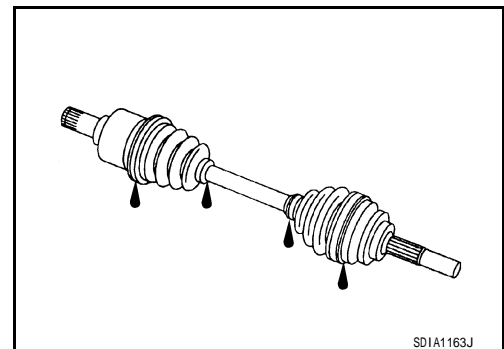

INSPECTION AFTER INSTALLATION

- Check wheel sensor harness for proper connection. Refer to [BRC-115, "FRONT WHEEL SENSOR : Removal and Installation \(GT-R certified NISSAN dealer\)"](#).
- Check the wheel alignment. Refer to [FSU-7, "Inspection"](#).
- Adjust neutral position of steering angle sensor. Refer to [BRC-10, "ADJUSTMENT OF STEERING ANGLE SENSOR NEUTRAL POSITION : Special Repair Requirement \(GT-R certified NISSAN dealer\)"](#).

FRONT DRIVE SHAFT

< ON-VEHICLE REPAIR >

FRONT DRIVE SHAFT

Exploded View (GT-R certified NISSAN dealer)

INFOID:000000003850223

LEFT SIDE

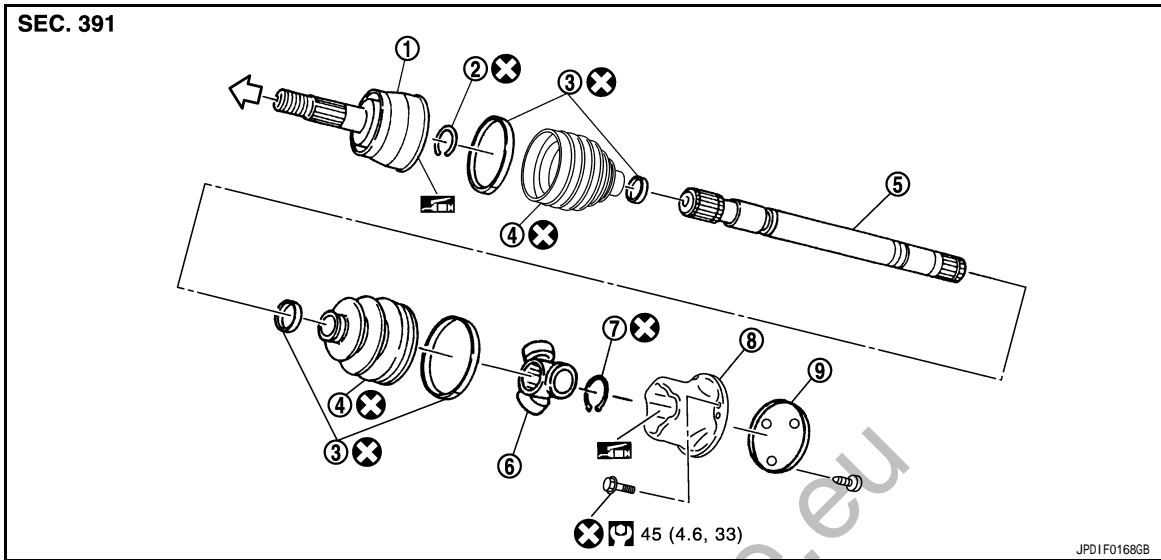

- | | | |
|-----------------------|------------------|--------------------|
| 1. Joint-sub assembly | 2. Circular clip | 3. Boot band |
| 4. Boot | 5. Shaft | 6. Spider assembly |
| 7. Snap ring | 8. Housing | 9. Plug |

⇐: Wheel side

: NISSAN genuine grease or an equivalent.

Refer to [GI-4, "Components"](#) for symbols not described on the above.

RIGHT SIDE

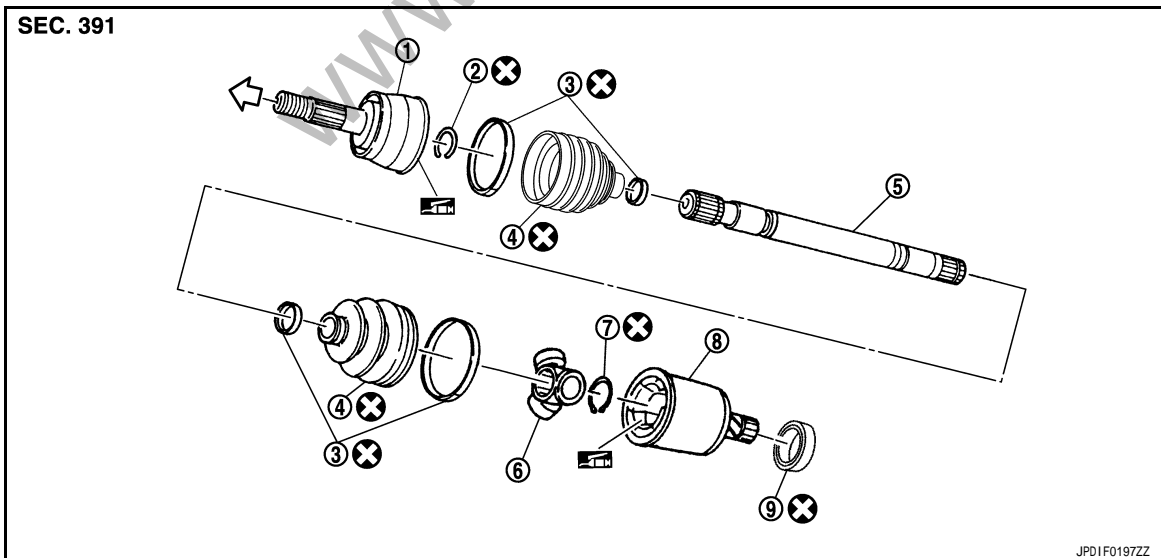

- | | | |
|-----------------------|------------------|--------------------|
| 1. Joint-sub assembly | 2. Circular clip | 3. Boot band |
| 4. Boot | 5. Shaft | 6. Spider assembly |
| 7. Snap ring | 8. Housing ring | 9. Dust shield |

⇐: Wheel side

FRONT DRIVE SHAFT

< ON-VEHICLE REPAIR >

 NISSAN genuine grease or an equivalent.

Refer to [GI-4, "Components"](#) for symbols not described on the above.

LEFT SIDE

LEFT SIDE : Removal and Installation (GT-R certified NISSAN dealer)

INFOID:000000003977656

REMOVAL

1. Remove tires with power tool.
2. Remove under cover. Refer to [EXT-35, "FRONT UNDER COVER : Exploded View"](#).
3. Remove steering knuckle. Refer to [FAX-8, "Exploded View"](#).
4. Remove stabilizer connecting rod. Refer to [FSU-18, "Exploded View"](#).
5. Remove shock absorber. Refer to [FSU-10, "Exploded View"](#).
6. Remove mounting bolts, and then remove drive shaft from vehicle.

INSTALLATION

Note the following, and install in the reverse order of the removal.

- When assembling the shaft, never press it, but pull it until fully seated by tightening the wheel hub lock nut.
- Check that anticorrosive oil is applied to the thread of the drive shaft. If not, apply appropriate oil such as engine oil.
- If sufficient oil is not applied to the thread of the drive shaft, the wheel hub lock nut may be seized and the tightening torque reaches the specified limit prematurely. It may cause looseness or abnormal noises.
- Perform the final tightening of each of parts under unladen conditions, which were removed when removing wheel hub and bearing assembly and steering knuckle.
- Never reuse cotter pin.

RIGHT SIDE

RIGHT SIDE : Removal and Installation (GT-R certified NISSAN dealer)

INFOID:000000003977656

REMOVAL

1. Remove tires with power tool.
2. Remove under cover. Refer to [EXT-35, "FRONT UNDER COVER : Exploded View"](#).
3. Remove steering knuckle. Refer to [FAX-8, "Exploded View"](#).
4. Remove stabilizer connecting rod. Refer to [FSU-18, "Exploded View"](#).
5. Remove shock absorber. Refer to [FSU-10, "Exploded View"](#).
6. Remove drive shaft from front final drive using the drive shaft attachment (A) [SST:KV40107500 (-)] and a sliding hammer (B) while inserting tip of the drive shaft attachment between housing and front final drive.

CAUTION:

Never place drive shaft joint at an extreme angle when removing drive shaft. Also be careful not to overextend slide joint.

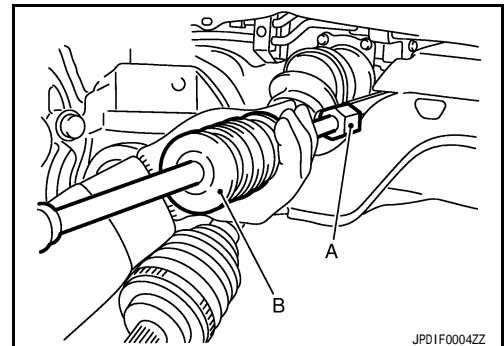

INSTALLATION

Note the following, and install in the reverse order of removal.

CAUTION:

Always replace final drive oil seal with new one when installing drive shaft. Refer to [DLN-69, "RIGHT SIDE : Exploded View \(GT-R certified NISSAN dealer\)"](#).

FRONT DRIVE SHAFT

< ON-VEHICLE REPAIR >

- Place the protector (A) [SST:KV38107900 (-)] onto final drive to prevent damage to the oil seal while inserting drive shaft. Slide drive shaft sliding joint and tap with a hammer to install.
- When assembling the shaft, never press it, but pull it until fully seated by tightening the wheel hub lock nut.
- Check that anticorrosive oil is applied to the thread of the drive shaft. If not, apply appropriate oil such as engine oil.
- If sufficient oil is not applied to the thread of the drive shaft, the wheel hub lock nut may be seized and the tightening torque reaches the specified limit prematurely. It may cause looseness or abnormal noises.
- Perform the final tightening of each of parts under unladen conditions, which were removed when removing wheel hub and bearing assembly and steering knuckle.
- Never reuse cotter pin.

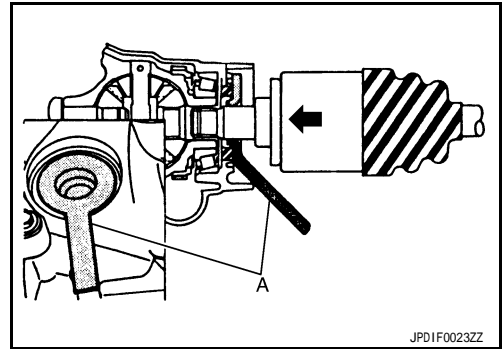

WHEEL SIDE

WHEEL SIDE : Disassembly and Assembly (GT-R certified NISSAN dealer)

INFOID:000000003977657

DISASSEMBLY

1. Fix shaft with a vise.

CAUTION:

Protect shaft when fixing with a vise using aluminum or copper plates.

2. Remove boot bands, and then remove boot from joint sub-assembly.
3. Screw drive shaft puller (A) 30 mm (1.18 in) or more into the thread of joint sub-assembly, and pull joint sub-assembly with a sliding hammer (B) from shaft.

CAUTION:

- Align sliding hammer and drive shaft and remove them by pulling firmly and uniformly.
- If joint sub-assembly cannot be removed after five or more unsuccessful attempts, replace shaft and joint sub-assembly as a set.

4. Remove circular clip from shaft.
5. Remove boot from shaft.

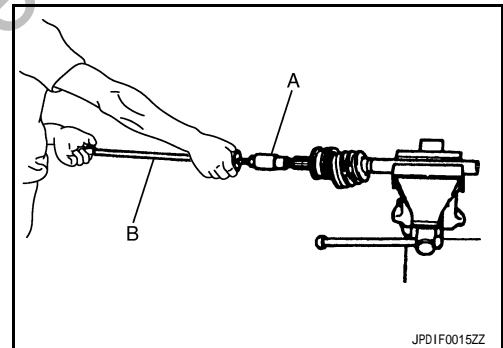

ASSEMBLY

1. Clean the old grease on joint sub-assembly with paper waste.
2. Fill serration slot joint sub-assembly (1) with NISSAN genuine grease or equivalent until the serration slot and ball groove become full to the brim.

CAUTION:

After applying grease, use a paper waste to wipe it out old grease that has oozed out.

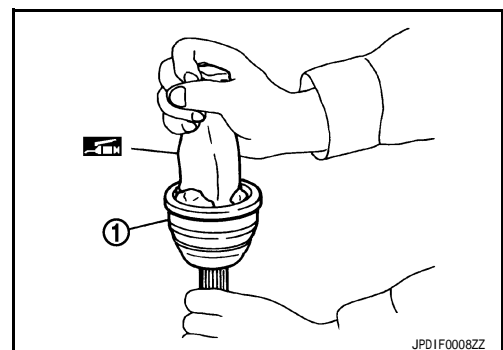

FRONT DRIVE SHAFT

< ON-VEHICLE REPAIR >

3. Wrap serration on shaft with tape (A) to protect the boot from damage. Install boot and boot bands to shaft.

CAUTION:

Never reuse boot and boot band.

4. Remove the tape wrapped around the serration on shaft.
5. Position circular clip on groove at the shaft edge.

CAUTION:

Never reuse circular clip.

NOTE:

Drive joint inserter is recommended when installing circular clip.

6. Align both center axes of the shaft edge and joint sub-assembly. Then assemble shaft with joint sub-assembly holding circular clip.

7. Install joint sub-assembly (1) to shaft using plastic hammer.

CAUTION:

Confirm that joint sub-assembly is correctly engaged while rotating drive shaft.

8. Apply the specified amount of grease into the boot inside from large diameter side of boot.

Standard

Grease amount : Refer to [FAX-22, "Drive Shaft \(GT-R certified NISSAN dealer\)"](#).

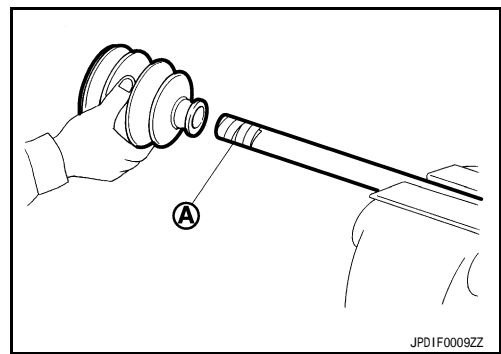

A
B
C

FAX

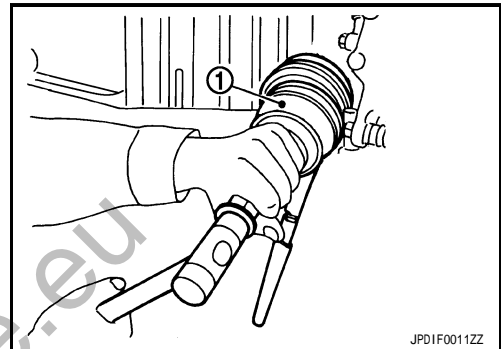

E
F
G
H

9. Install the boot securely into grooves (indicated by "*" marks) shown in the figure.

CAUTION:

If grease adheres to the boot mounting surface (indicated by "*" mark) on the shaft or joint sub-assembly, boot may come off. Remove all grease from the surface.

10. To prevent from the deformation of the boot, adjust the boot installation length (L) to the specified value shown below by inserting the suitable tool into inside of the boot from the large diameter side of the boot and discharging the inside air.

Standard

L : Refer to [FAX-22, "Drive Shaft \(GT-R certified NISSAN dealer\)"](#).

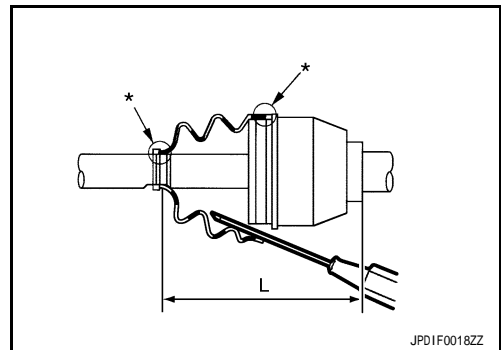

I
J
K
L

CAUTION:

- If the boot mounting length is outside the standard, it may cause breakage in the boot.
- Be careful not to touch the inside of the boot with a tip of tool.

11. Secure the ends of the boot with boot bands using the boot band crimping tool (A) [SST: KV40107300 (-)].

CAUTION:

Never reuse boot band.

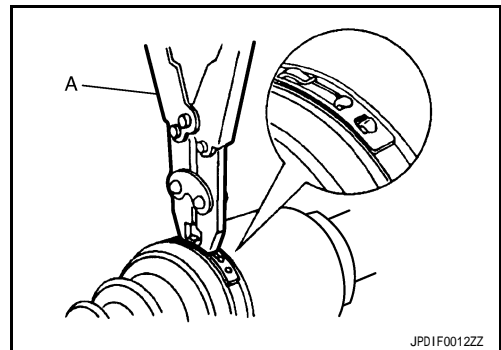

M
N
O
P

NOTE:

FRONT DRIVE SHAFT

< ON-VEHICLE REPAIR >

Secure boot band so that dimension (M) meets the specification as shown in the figure.

M : 2.0 – 3.0 mm (0.079 – 0.118 in)

- Secure joint sub-assembly and shaft, and then check that they are in the correct position when rotating boot. Install them with boot band when boot installation positions become incorrect.

CAUTION:
Never reuse boot band.

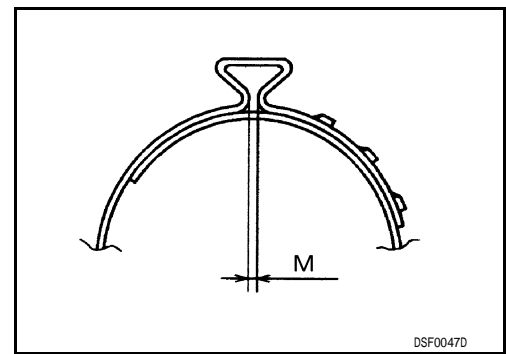

FINAL DRIVE SIDE

FINAL DRIVE SIDE : Disassembly and Assembly (GT-R certified NISSAN dealer)

INFOID:000000003977658

DISASSEMBLY

- Fix shaft with a vise.

CAUTION:
Protect shaft when fixing with a vise using aluminum or copper plates.

- Remove boot bands, and then remove boot from housing.
- If plug needs to be removed, remove with a screw. (Left side)
- Remove dust shield. (Right side)
- Put matching marks on housing and shaft, and then pull out housing from shaft.

CAUTION:
Use paint or similar substance for matching marks. Never scratch the surfaces.

- Put matching marks (A) on the spider assembly and shaft.

CAUTION:
Use paint or similar substance for matching marks. Never scratch the surfaces.

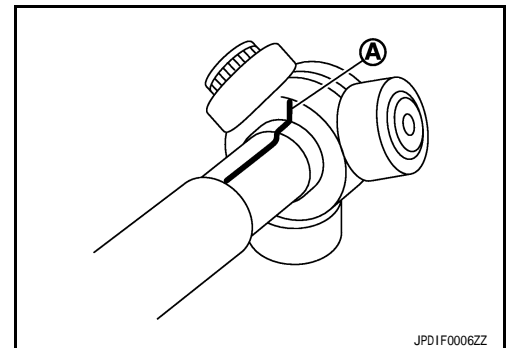

- Remove snap ring (1), and then remove spider assembly from the shaft.
- Remove boot from the shaft.

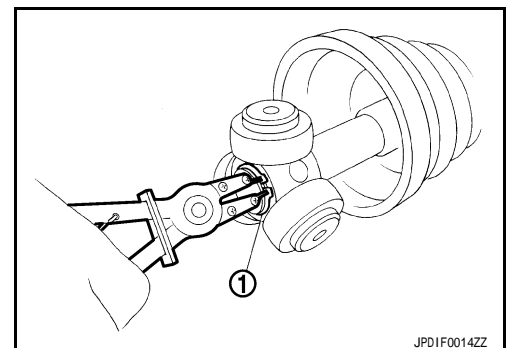

ASSEMBLY

- Clean old grease on housing with paper waste.

FRONT DRIVE SHAFT

< ON-VEHICLE REPAIR >

- Plug (1) has been removed, install a plug to housing (2) with a screw. (Left side)
- Install dust shield to housing. (Right side)

CAUTION:

Never reuse dust shield.

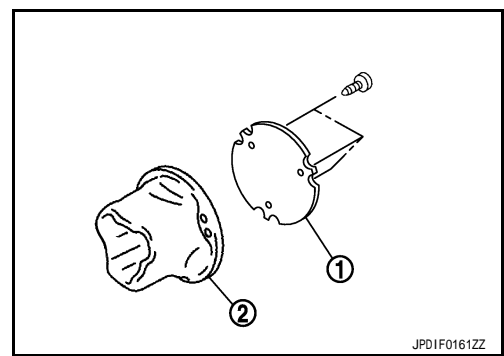

- Wrap serration on shaft with tape (A) to protect boot from damage. Install boot and boot bands to shaft.

CAUTION:

Never reuse boot and boot band.

- Remove the tape wrapped around the serration on shaft.

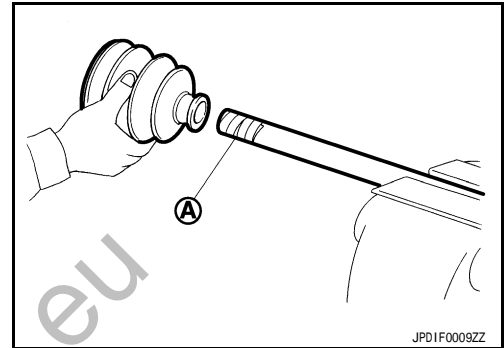

- Install the spider assembly (1), align it with the matching marks (A) on the shaft (2) during the removal, and direct the serration mounting surface (B) to the shaft.

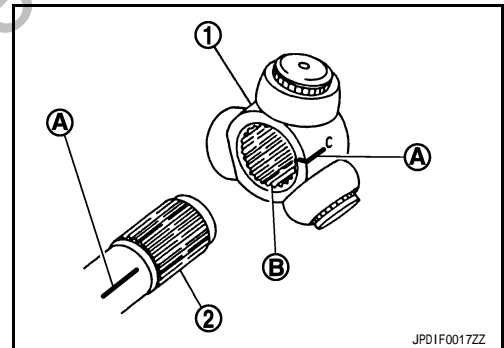

- Assemble spider assembly onto shaft with snap ring (1).
- CAUTION:**
Never reuse snap ring.
- Apply the appropriate amount of grease to spider assembly and sliding surface.
 - Assemble the housing onto spider assembly, and apply the specified amount grease.

Standard

Grease amount : Refer to [FAX-22, "Drive Shaft \(GT-R certified NISSAN dealer\)"](#).

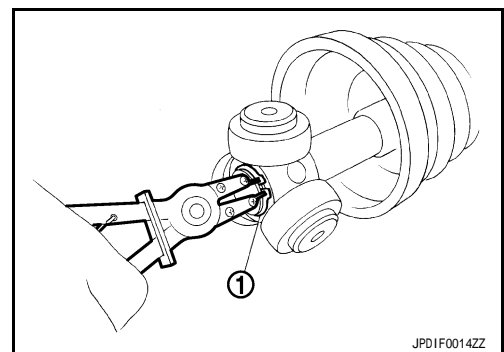

- Align matching marks painted when housing was removed.
- Install the boot into grooves (indicated by "*" marks) shown in the figure.

CAUTION:

If grease adheres to the boot mounting surface (indicated by "*" mark) on shaft or housing, boot may come off. Remove all grease from the surface.

FRONT DRIVE SHAFT

< ON-VEHICLE REPAIR >

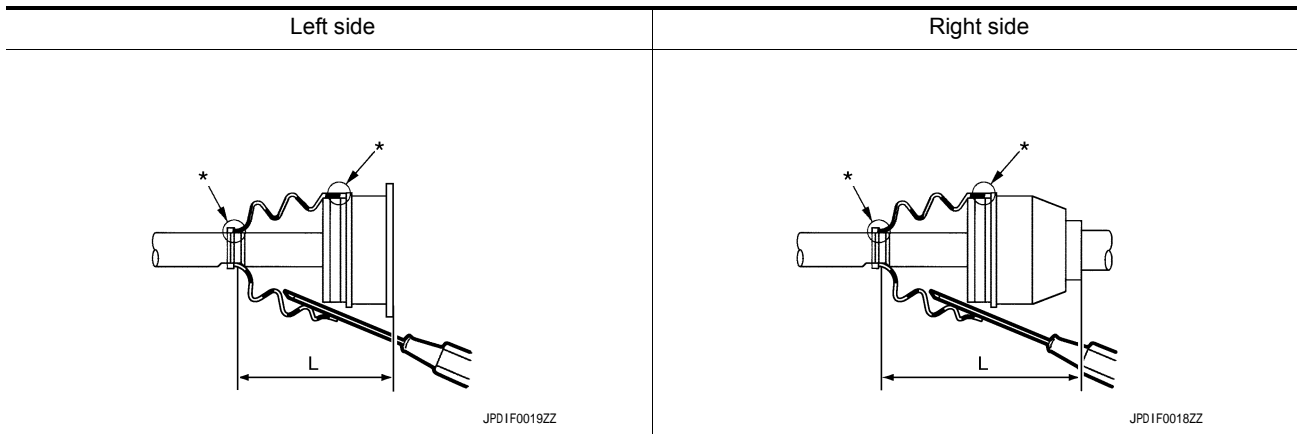

12. To prevent deformation of the boot, adjust the boot installation length (L) to the value shown below by inserting the suitable tool into the inside of boot from the large diameter side of boot and discharging inside air.

Standard

L : Refer to [FAX-22, "Drive Shaft \(GT-R certified NISSAN dealer\)"](#).

CAUTION:

- If the boot installation length is outside the standard, it may cause breakage in boot.
- Be careful not to touch the inside of the boot with the tip of tool.

13. Install boot bands.

CAUTION:

Never reuse boot band.

- a. Put boot band in the groove on drive shaft boot. Then fit pawls (←) into holes to temporary installation.

NOTE:

For the large diameter side, fit projection (A) and guide slit (B) at first.

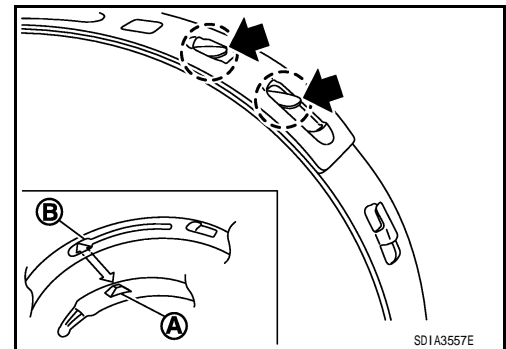

- b. Pinch projection on the band with suitable pliers to tighten band.
c. Insert tip of band below end of the pawl.

14. Secure housing and shaft, and then check that they are in the correct position when rotating boot. Install them with boot band when the mounting positions become incorrect.

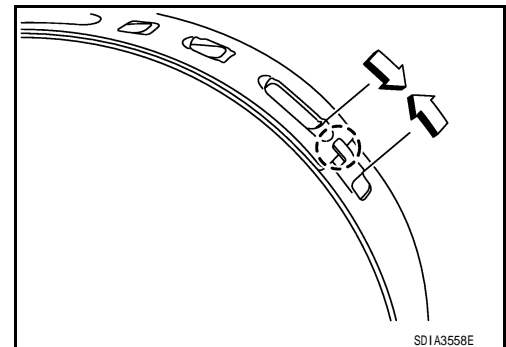

Inspection (GT-R certified NISSAN dealer)

INFOID:000000003977659

INSPECTION AFTER REMOVAL

- Move joint up/down, left/right, and in the axial directions. Check for motion that is not smooth and for significant looseness.

FRONT DRIVE SHAFT

< ON-VEHICLE REPAIR >

- Check boot for cracks, damage, and leakage of grease.
- Disassemble drive shaft and exchange malfunctioning part if there is abnormal condition.

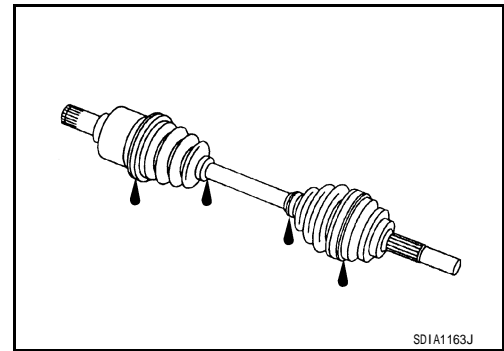

INSPECTION AFTER INSTALLATION

1. Check shock absorber actuator harness connector. Refer to [FSU-10, "Removal and Installation \(GT-R certified NISSAN dealer\)"](#).
2. Check wheel sensor harness for proper connection. Refer to [BRC-115, "FRONT WHEEL SENSOR : Removal and Installation \(GT-R certified NISSAN dealer\)"](#).
3. Check the wheel alignment. Refer to [FSU-7, "Inspection"](#).
4. Adjust neutral position of steering angle sensor. Refer to [BRC-10, "ADJUSTMENT OF STEERING ANGLE SENSOR NEUTRAL POSITION : Special Repair Requirement \(GT-R certified NISSAN dealer\)"](#).

INSPECTION AFTER DISASSEMBLY

Shaft

Check shaft for runout, cracks and other damage. Replace it if necessary.

Joint Sub-Assembly (Wheel Side)

Check the following items, replace the parts if necessary.

- Joint sub-assembly for rough rotation or excessive axial looseness.
- The inside of the joint sub-assembly for entry of foreign material.
- Joint sub-assembly for compression scars, cracks or fractures inside of joint sub-assembly.

Replace joint sub-assembly if there are any abnormal conditions of components.

Housing and Spider assembly (Final Drive side)

Replace housing and spider assembly if there is scratching or wear of housing roller contact surface or spider roller contact surface.

NOTE:

Housing and spider assembly are used in a set.

A
B
C

FAX

E
F
G

H
I
J

K
L
M

N
O
P

SERVICE DATA AND SPECIFICATIONS (SDS)

< SERVICE DATA AND SPECIFICATIONS (SDS)

SERVICE DATA AND SPECIFICATIONS (SDS)

SERVICE DATA AND SPECIFICATIONS (SDS)

Wheel Bearing (GT-R certified NISSAN dealer)

INFOID:000000003850232

Item	Standard
Axial end play	0.05 mm (0.002 in) or less

Drive Shaft (GT-R certified NISSAN dealer)

INFOID:000000003850233

Item	Left side		Right side	
	Wheel side	Final drive side	Wheel side	Final drive side
Grease quantity	Wheel side	77 – 97 g (2.72 – 3.42 oz)		
	Final drive side	95 – 105 g (3.36 – 3.70 oz)	113 – 123 g (3.99 – 4.33 oz)	
Boots installed length	Wheel side	136 mm (5.35 in)		
	Final drive side	151.9 mm (5.98 in)	158.6 mm (6.24 in)	

www.gtr-store.eu